

**DIMENSIONS**

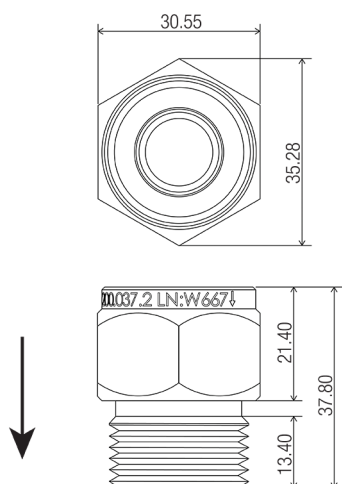

**INDICATIVE IMAGE**

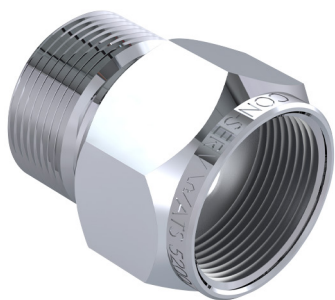

**WHISPER WASH® - MK 1**

**Product Code - Finish**

- AF 048 C/09 - Chrome

**Features**

- 3/4" F & M DR brass (20 mm), 38 mm long flow regulator non-return valve
- For appliance noise reduction
- Suitable for washing machines, dishwashers and all water-using appliances with 3/4" BSP hose connections
- Equipped with stainless steel filter screen
- Chrome

**Compliance**

- Watermark AS 5200.037.2 Licence WMKA 00667

**Warranty**

See Con-Serv warranty policy for full details.

**CON-SERV CORPORATION AUSTRALIA PTY. LTD.**

17 Glentanna Street, Kedron · Qld. 4031 Australia

Phone: +61 (0)7 3630 5744 · Fax: +61 (0)7 3630 5755 · Email: mail@con-serv.com.au · www.con-serv.com.au